

DB-2021S

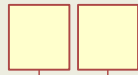

\_ : Install right hand side

L : Install left hand side

\_ : Use break fluid (vegetable oil)

K : Use mineral oil

◆ Main Features

- Hydraulic Applied - Spring Released
- Coefficient of dynamic friction : 0.3
- For thicker disc than DB-2021S series.

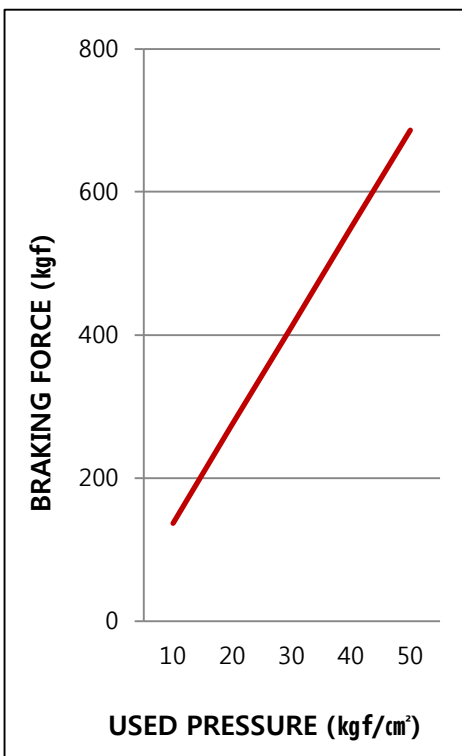
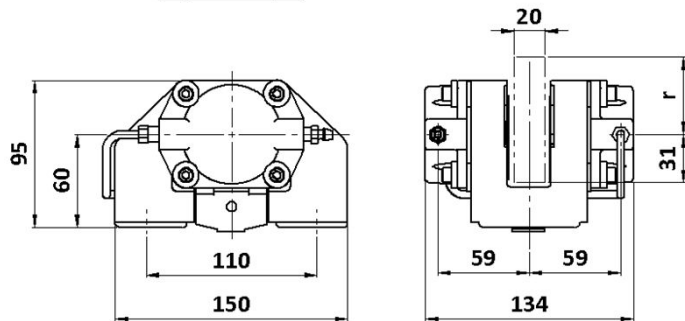
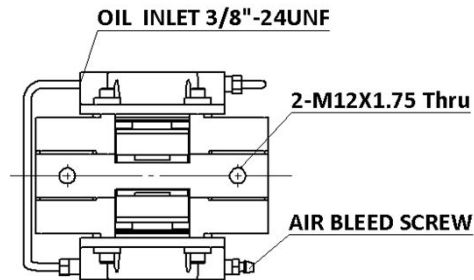

Specification		DB-2021S
Size of Cylinder	mm	55(2-1/8")
Area of Cylinder	cm <sup>2</sup>	22.88
Usable Disc Dia.	mm	Ø220 ~ ∞
Disc Thickness	mm	20
Effective Radius of Braking	m	r=1/1000(Disc Dia/2-31)
Size of Pad Lining (Length x Width x Thickness)	mm	47.5 x 53.97 x 16.7
Wear Allowance of Pad Lining	mm	10
Max. Working Oil Pressure	kgf/cm <sup>2</sup>	50
Required Oil Volume	cc	2.5
Weight	kg	5.3
Torque Calculation (Braking Force=BF, kgf)	kgf-m	T=BF x r