

**CWB-90** (Spring Applied Hydraulic Released)

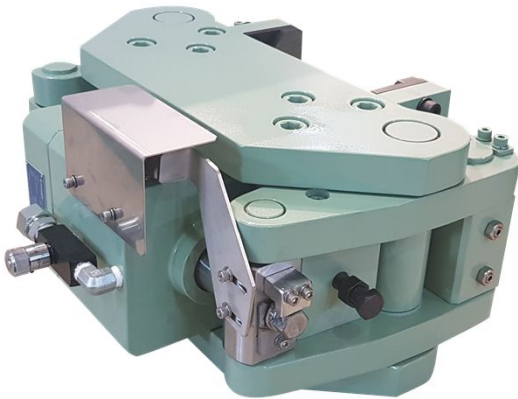

◆ **Operating Condition**

- Ambient temperature : -10°C ~ +60°C
- Other condition : consult CHASCO

◆ **Use**

- The Brakes are failsafe type.
- Wheel brake acts directly on the wheel.

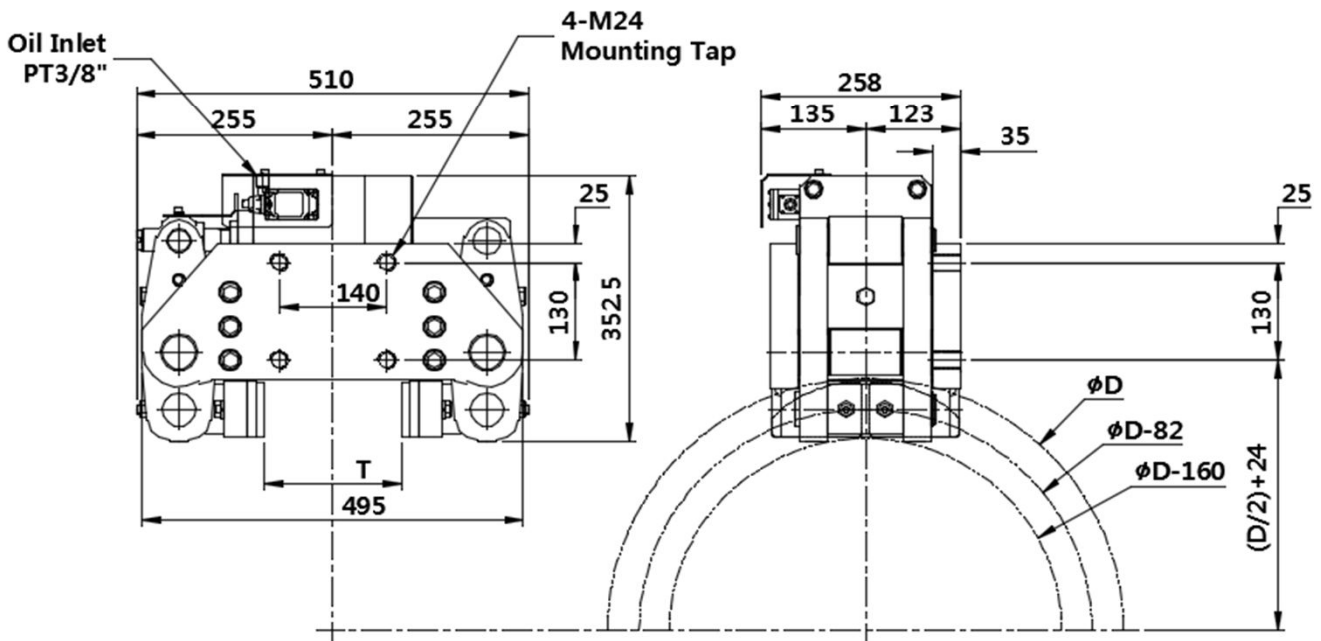

Specification		CWB-90
Clamping Force (CF) for 1mm of Air Gap (disc / lining) each side	kN	90
Working Release Pressure	Min. kgf/cm <sup>2</sup>	45
	Max. kgf/cm <sup>2</sup>	75
Wear Allowance of Pad Lining	mm	5
Required Oil Volume (air gap for 2mm)	cc	126
Wheel Width (T)	mm	Min. 60 ~ Max. 200
Weight	kg	180