

CTB-25

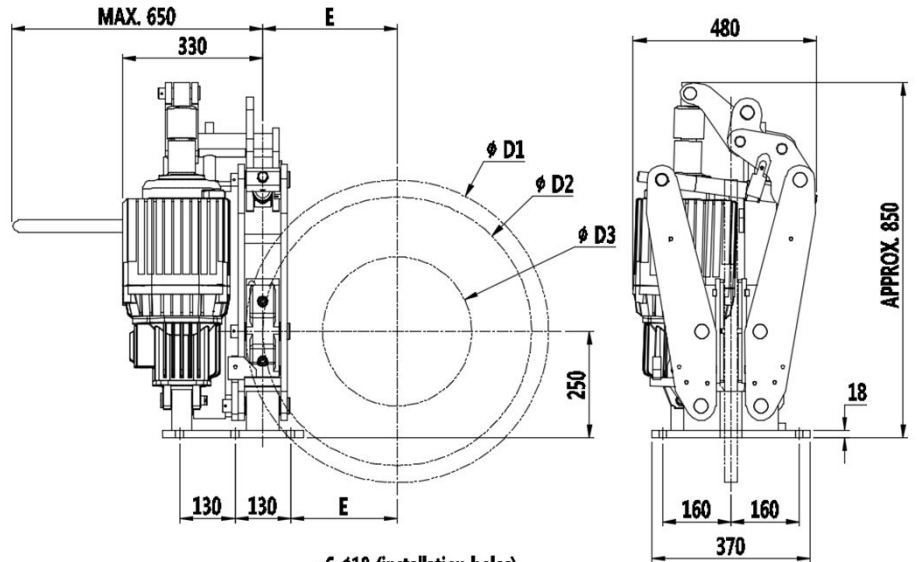

◆ **Main Features**

- Automatic wear compensator
- Adjustable, enclosed brake spring with clamping force scale
- Limit switch release control
- Manual release lever

◆ **Order Information**

- Model Type - Thruster Type - Direction
- CTB-25- -

: Install right hand side
 L : Install left hand side
 Thruster Type

- The installation holes can be customized by PO.

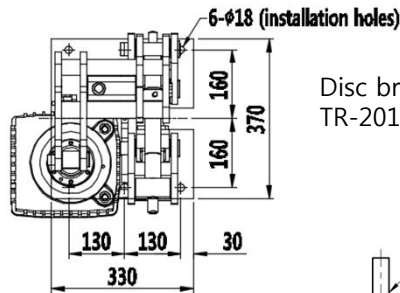

Disc brake shown with TR-201/80 in right hand version

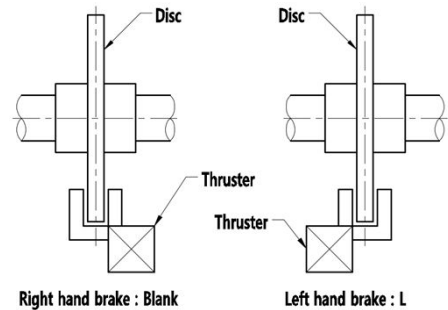

◆ **Specification**

Weight : 120kg without thruster		Thruster Type			TR-201/80
		Clamping Force in N			24000
Disc Ø	Friction Ø				Brake Torque BT in Nm
D1	D2	D3	E	K	Friction static $\mu = 0.4$
400	320	170	160	95	3070
450	370	200	185	120	3550
500	420	230	210	145	4030
560	480	260	240	175	4610
630	550	300	275	210	5280
710	630	350	315	250	6040