

CB-8100A-A (Adjustable Hydraulic Booster)

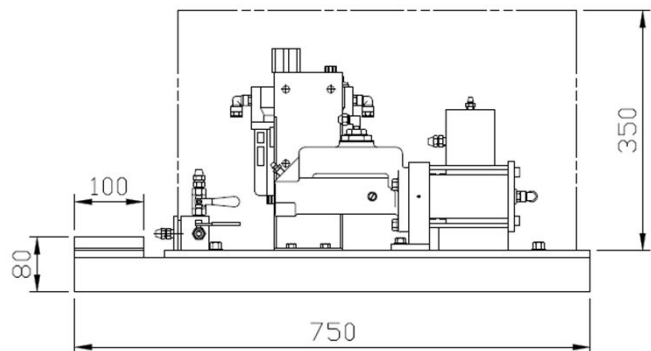
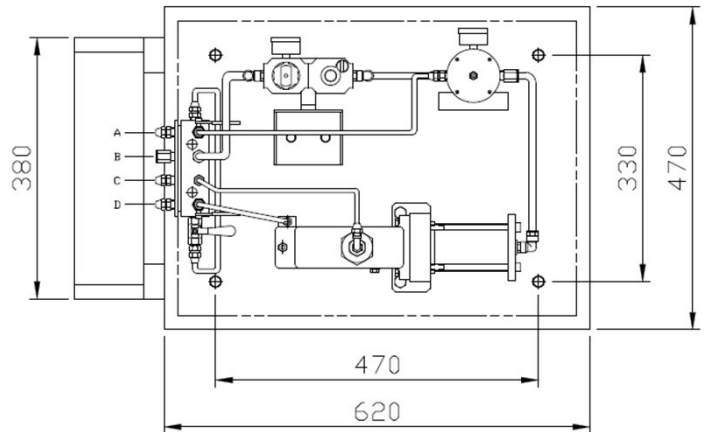

◆ **Operating Condition**

- Ambient temperature : -10°C~+60°C
- Relative humidity : ≤ 70%
- Dust in atmosphere : ≤ 65μ
- Other condition : consult CHASCO
- Oil to be used : Use brake oil

◆ **Use**

- Port A is connected Foot Pedal Unit
- Port B is connected Air Compressor
- Port C is connected Oil Tank
- Port D is connected caliper
- Our booster is normally open type(A type booster).
- Our booster has enough capacity to brake a big facility.
- It can simultaneously control high load brakes on several points using only small power.
- This product is patented by the Korean Intellectual Property Office. (patent No. 0319193)

◆ **Specification**

Model Type	CB-8100A-A	
Master Cylinder	Cylinder Size	1-1/2"
	Discharge Oil Volume	50cc
Air Cylinder	Cylinder Size	Ø50 mm
	Air volume	120cc
Air Unit F.R.L	Max Air Pressure	5kg/cm ²