

HPM-23

• Designed and produced by customer order.

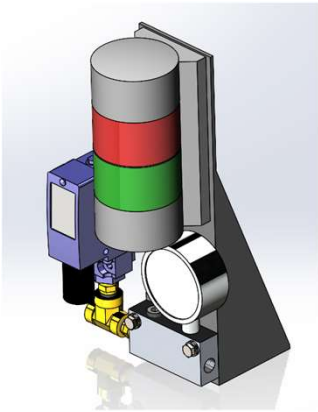

- Monitors whether the regular pressure is supplied
- Installed in pipeline between the booster and caliper
- Pressure Range adjustable : 7 ~70 kgf/cm²
- Mechanical Pressure gage incorporated
- Electromechanical pressure sensor incorporated
- Connection Ports : PT 1/4"
- Signaled Light Color : (Red) Pressure On, (Green) Pressure Off

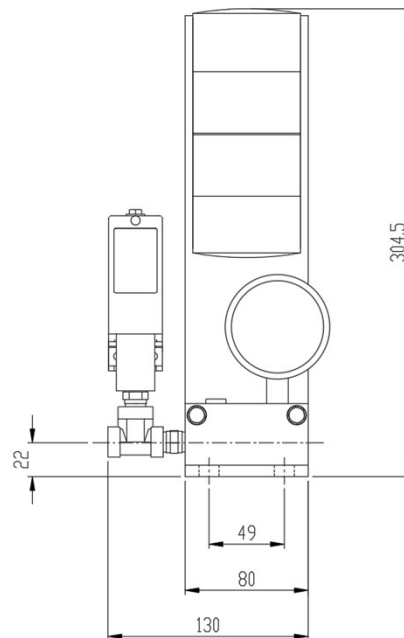
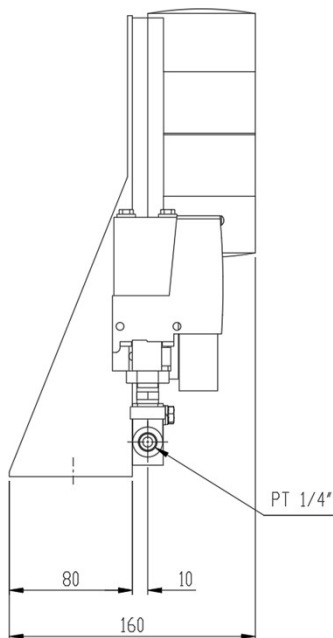

◆ Specification

Power	220V AC (other options available)
Pressure Range	7 ~70 kgf/cm ²
Maximum pressure allowed	100 kgf/cm ²
Sensor Destruction pressure	320 kgf/cm ²
Weight (Kg)	2.7 kg
Signaling Color	Red and Green